

Can Bluetooth And 802.11b Co-Exist?

CARVING OUT SPACE FOR WIRELESS COMMUNICATION BASED ON ESTABLISHED STANDARDS IN THE CROWDED 2.4-GHz ISM BAND MIGHT BE MORE DIFFICULT THAN FIRST THOUGHT.

BY CHERYL AJLUNI

WIRELESS local-area networks (WLANs) are soon expected to be the most prevalent public broadband-access method, providing optimal end-user mobility, simple installation, low cost, and easy system scalability. Roughly three to four years from now, 1 billion Bluetooth devices will be in the hands of consumers. Both the WLAN and Bluetooth devices occupy the same 2.4-to-2.483-GHz unlicensed frequency range—the same band, by the way, that is also occupied by a number of other devices such as microwave ovens and cellular phones. Does anyone see a problem here?

The problem is interference—the dreaded “I” word that wreaks havoc with even the most seasoned wireless

systems designer—and it is not going away any time soon. The root of the problem boils down to modulation schemes. The 802.11b-compliant WLANs are modulated using direct-sequence, spread-spectrum (DSSS) technology, while Bluetooth-compliant products rely on frequency-hopping, spread-spectrum (FHSS) technology. FHSS is somewhat immune to narrowband interference because it essentially hops around other devices. Since Bluetooth devices use extremely low transmission power—approximately 0.01 W—more powerful devices, such as an 802.11b WLAN, can overpower the Bluetooth signal.

According to Dennis Eaton, strategic marketing man-

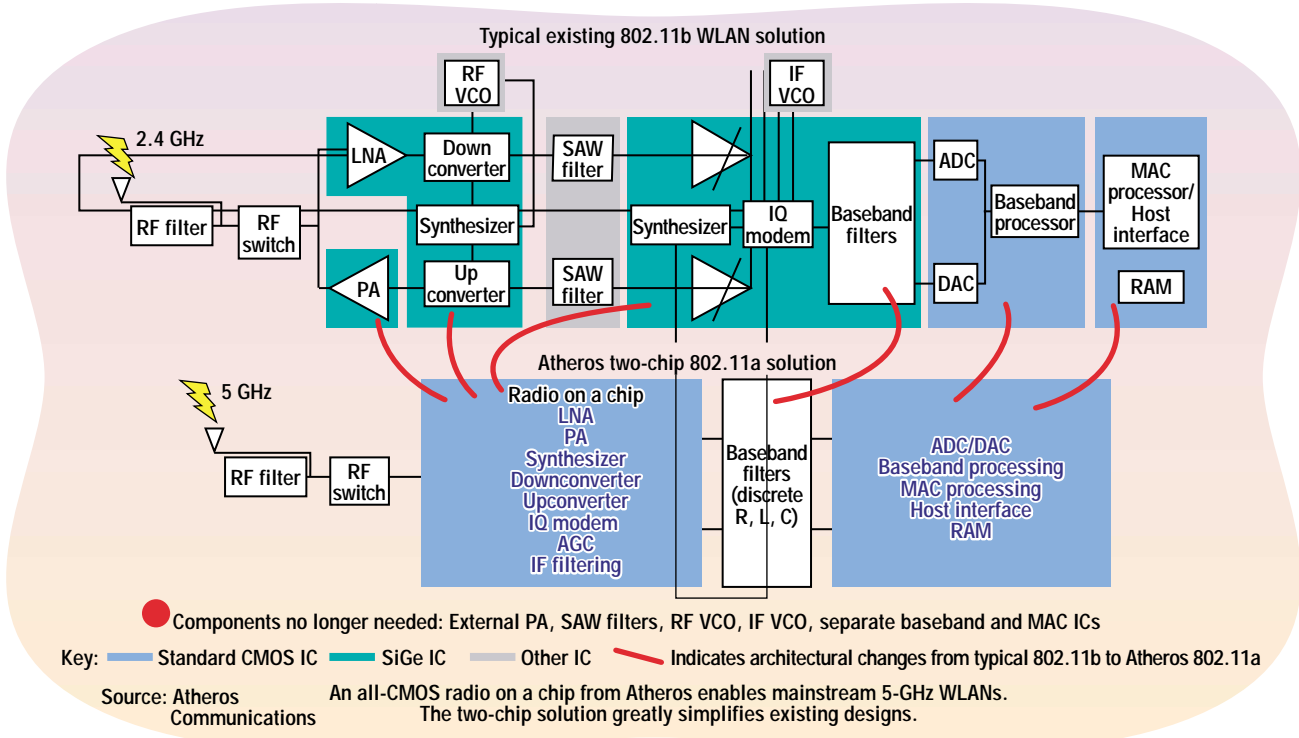

1. Shown here is Atheros' all CMOS radio-on-a-chip that enables mainstream 5-GHz WLANs. Since it operates at the higher frequency band, it is not subject to interference problems such as those currently impacting 2.4-GHz WLANs and Bluetooth devices.

WLAN DEVICES

ager with Intersil Corp. (Irvine, CA), "For Bluetooth systems this interference can show up in the form of transmission errors when the current 1-MHz hop channel falls into one of the static 17-MHz 802.11b channels. Similarly, for 802.11b systems, interference can occur when the current Bluetooth hop channels enter the 802.11b channel while a transmission is occurring. Additionally, due to the clear-channel assessment mechanism of 802.11b, interference can also occur if a Bluetooth transmitter hops into the 802.11b channel prior to transmission. In this case, the 802.11b system will defer transmission, sensing that another station is currently active on the channel."

Essentially then, since the 802.11b WLAN standard and Bluetooth operate in the same band, there will inevitably be instances of mutual interference. The result might be as minor as degraded performance or as extreme as device non-function. The level of interference will depend on the usage scenario of each system, as well as how close the opposing devices are to one another.

Jan Haagh, ORiNOCO product manager at Lucent Technologies (Nieuwegein, The Netherlands) argues that getting to that extreme may not be a realistic assessment of the issue. "Although both Bluetooth and IEEE 802.11b use the same frequency band, analysis and tests have shown that the mutual impact of both systems is minimal. If there

is any impact, it will come in the form of 'graceful degradation.' That means that one system will not stop the other from operating, but that there will be a performance impact."

Previous analysis may very well have proven Jan's assessment to be valid under a typical usage scenario. Times are changing though, and so too must the original interference assessment. Currently, testing is underway to validate interference levels in an environment where Bluetooth radios are widely available.

While some may disagree on the result of the interference, no one disagrees that it exists or that it must be addressed before it has a chance to get out of hand. Unfortunately though, since the problem is being dealt with after the fact, so to speak, options are much more limited. It is not a matter of eliminating the source of the interference, but rather of finding ways to work around it.

One work-around option, according to Carl Temme, director of product management at Atheros (Sunnyvale, CA), is to simply migrate to the 5-GHz frequency band. As he explains, "Five GHz is much more amenable

to wireless LANs. There is the technical challenge of figuring out how to do it at this frequency, but once you do that it is fairly straightforward. Five GHz is just better for WLANs. The 2.4-GHz band is better suited to personal-area networks (PANs) like Bluetooth." Atheros has opted to take this route and it now offers a 5-GHz radio product (Fig. 1).

Considering the investment most WLAN vendors have made at 2.4 GHz, it is a fairly safe bet there will be no mass exodus to the 5-GHz range in the immediate future. Instead, most will opt to use work-arounds. What are the possible work-arounds? At the highest level, a potential solution might involve managing the radio spectrum use of both systems (Fig. 2). Another option would entail changing the way in which wireless devices use the 2.4-GHz frequency. Raylink, Inc. (Baldwin Park, CA), for example, manufactures 802.11 FHSS wireless network products. Its choice of the FHSS protocol allows the products it produces to co-exist with many types of wireless LAN protocols including 802.11b, Bluetooth, and Home RF.

For embedded applications where Bluetooth and 802.11 exist on the same platform, a number of options exist to control device interaction. Intersil's Dennis Eaton suggests antenna-pattern-shaping techniques that increase isolation between the two radios by limiting the coverage overlap between them. A common software driver might also be used to control both radios. Finally, a modal form of operation could be utilized in some usage scenarios to allow the operation of only one radio type at any particular time.

In this instance Intersil is one company that practices what it preaches. Currently, the company is engaged with Silicon Wave (San Diego, CA) in the development of dual-mode 802.11b/Bluetooth radio technology. With such technology, Bluetooth and 802.11b would be able to peacefully co-exist.

Chris Fisher, vice president of sales and marketing with Radiata, Inc. (San Jose, CA), boasts a slightly different take on the matter. Fisher states, "There is really nothing that can be done to eliminate the interference problem other than to build systems that operate at non-interfering frequencies. The IEEE 802.11a standard, for example, utilizes a set of frequencies known as the unlicensed-national-information-infrastruc-



2. Pictured here is Berkeley Varitronics' (Metuchen, NJ) IEEE 802.11 WLAN Grasshopper product. This handheld receiver measures signal strength, bit-error rates (BERs), and even shows multipath energy. Additionally, it provides real-time display of key parameters to enable installers to optimize placement of nodes and identify sources of interference.

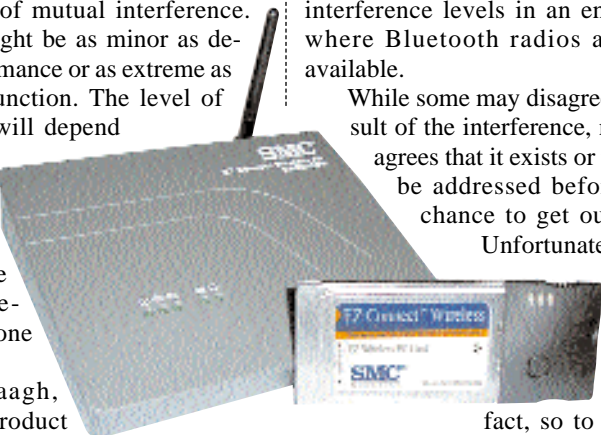

3. According to Tony Stramandinoli, director of product marketing with SMC Networks (Irvine, CA), "The home network of the future will need to support devices including data, video, cordless phones, and Internet appliances. Wireless technology is the perfect solution. Of the three wireless technologies currently available, none of them can transmit data faster than 11 Mb/s. SMC Networks now has a new line of 11-Mb/s wireless products known as EZ Connect Wireless. They provide an easy alternative to wired networks both in the home and office environment, supporting temporary work sites and mobile users."

WLAN DEVICES

ture (UNII) band (5.15 to 5.35 GHz and 5.725 to 5.825 GHz). Systems that comply with this standard not only benefit from interference-free operation, but also have a significantly improved data rate (54 Mb/s versus 11 Mb/s for 802.11b and 1 Mb/s for Bluetooth). In addition, a new technology specifically designed for the indoor radio environment—coded orthogonal frequency-division multiplexing (COFDM)—is utilized as opposed to spread spectrum. The net result is a very-high-performance system that does not suffer the interference problems or performance limitations of 2.4-GHz systems.”

Each option cited obviously has its benefits and limitations. While WLAN and Bluetooth vendors attempt to identify which one might possibly serve them best, industry organizations have pledged not to sit idly by waiting to see how things turn out. Rather, a host of industry activities are now underway to proactively address co-existence options. One activity centers on the repeal of a rule requiring Bluetooth radios to hop over the entire 2.4-GHz band. If instead, these radios could limit their hop to a narrow portion of the band, use of adaptive hopping algorithms might be plausible. The result would be the elimination of any potential collisions between Bluetooth and 802.11b WLANs.

In addition, working groups charged with investigating and resolving the co-existence issue have been established by the IEEE 802.11 Committee, Bluetooth Special Interest Group (SIG), and the Wireless Ethernet Compatibility Alliance (WECA). A “recommended-practices” document is expected to be released by the IEEE 802.15.2 group. This publication will provide a range of options for consideration on the topic of Bluetooth and 802.11 co-existence.

At some point, the issue of co-existence may prove to be a mute point. That is because Bluetooth and 802.11b each have their own application space. Blue-



4. Radiata's 802.11a-based wireless engine chip set is pictured here. This product was announced in September 2000 and consists of two chips—a baseband modem (R-M11a) and a 5-GHz UNII band radio transceiver (R-RF5). With much anticipation, chip vendors such as Radiata are now making available silicon solutions that allow companies to implement these new technologies (5-GHz 802.11a) at price points equivalent or near parity to many of the existing 2.4-GHz technologies. It is anticipated that end-user products (NICs and Access Points) will become available in the second half of 2001.

tooth is primarily targeted at short-range communication, while the 802.11 WLAN standard is geared toward providing a seamless, wireless, high-speed data connection. Thanks to high-speed data specifications, such as the 11-Mb 802.11b and 802.11a standards, those speeds are going up and driving WLAN technology to the 5-GHz range with its greater bandwidth. In the process, a whole new slew of applications, such as enterprise networks and those requiring increased voice and video content, are being enabled. This might include things like multimedia-intensive applications for the home or office networks (Fig. 3). Such applications require in excess of 22 Mb/s of total system capacity to seamlessly transmit multiple streams of digital audio and video.

As the need for bandwidth and increased speed grows, many WLAN equipment providers may seek to offer 5-GHz 802.11a products (Fig. 4). In the meantime, given the continued growth in both the Bluetooth and 802.11b wireless technology spaces, there is little doubt that steps must be taken to ensure that the services each provides at the 2.4-GHz frequency range co-exist peacefully. If not, many consumers may learn the hard way that wireless technology, like other technology, is not always all that it is cracked up to be. When that happens, wireless vendors will be the real losers. **WSD**