

Intermod: Getting the upper hand (Part 2)

By Harold Kinley

“An ounce of prevention is worth a pound of cure” certainly applies to the problem of intermodulation interference. Several methods are used to get the upper hand on intermodulation interference. The method used to suppress the IM will depend on where the IM is generated.

Figure 1 shows an RF amplifier with two signals (*A* and *B*) ap-

plied to the input. Third-order intermod signals, $2A - B$ and $2B - A$, will appear at the output of the amplifier. Other products will appear at the output as well. However, this discussion will be limited to the third-order IM products. The level of the third-order IM products at the ampli-

fier output will depend on the level of the *A* and *B* signals at the input and the third-order intercept point (TOIP) of the amplifier. Table 1 illustrates the relationship between input levels: the TOIP and IM levels at the amplifier output. In column A, the amplifier’s TOIP is +5dBm. This is a low-quality amplifier. Column A further indicates that if the input levels are at -10dBm, the IM levels at the amplifier output are at -40dBm. In column B, the input levels are the same as column A; but, the TOIP of the amplifier is +10dBm and the IM levels at the amplifier output have dropped to -50dBm. Note that the *drop* in the IM level is equal to *twice* the amount of the *increase* in the TOIP. In column C, the TOIP increases by 10dB over column B and the IM level in column C drops by 20dB.

This illustrates the importance of using an amplifier with a high TOIP. Amplifiers with TOIPs much higher than this are used in situations where greater IM suppression is a must. However, these higher-quality amplifiers are accompanied by a higher price tag. It’s still true—you don’t get something for nothing. Install a cheap amplifier in front of a receiver in a densely populated site, and

won’t for long.

Refer again to Table 1. Column D shows the two input signals at -13dBm. That is 3dB down from column C. Yet, the output levels of the IM signals are 9dB down from column C. Thus, we have realized a three-fold reduction in the IM signal level compared to the input signals. This is a characteristic of the IM mixing process. For third-order IM, a reduction of 1dB in each of the input signals (*A* and *B*) causes a drop of 3dB in the IM signals. So, for third-order IM we get a three-for-one advantage. That is, for every decibel of attenuation in the input signals, we get a 3dB reduction in the IM product. With fifth-order products, we get a five-for-one reduction. This can be generalized as such: A reduction of 1dB to the intermod-forming input signals will yield *N* decibels of reduction to IM signal for an *N*th-order IM signal. This reduction must occur ahead of the mixing point. This is an important characteristic—one that can be used to our advantage in suppressing IM levels.

In Table 1, examine column E. Here, the input signal levels are increased by 1dB compared to column C (from -10 to -9dBm). Yet, the IM signals at the output have increased by 3dB. This is the reverse of the above situation where the input signals were reduced. This still complies with the IM mixing rules. A change in the levels of the IM forming signals ahead of the mixing point will result in a greater change in the IM signal by an amount equal to the order of the

you will hear things you have never heard before—and wish you wouldn’t hear.

If you are lucky enough to have a site where an amplifier can help, then use the highest quality available. Though you might get away with using a lower-quality amplifier today, you probably

Contributing editor Kinley, *MRT’s* technical consultant and a certified electronics technician, is regional communications manager, South Carolina Forestry Commission, Spartanburg, SC. He is the author of *Standard Radio Communications Manual, with Instrumentation and Testing Techniques*, which is available for direct purchase. Write to 204 Tanglewylde Drive, Spartanburg, SC 29301. His email address is halkinley@charter.net.

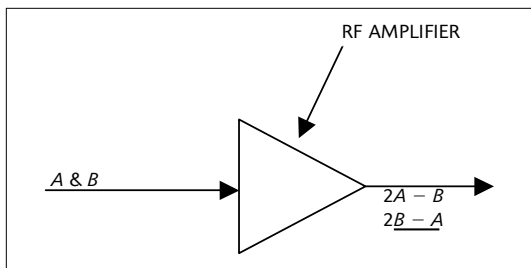

Figure 1: If two input signals, *A* and *B*, are applied to the input of an amplifier, the mixing process would produce two intermodulation products, $2A - B$ and $2B - A$. The level of the IM products at the output of the amplifier will depend on the levels of *A* and *B* at the input and the third-order intercept point of the amplifier. The TOIP is a theoretical figure and one used to quantify the intermodulation rejection ability of the amplifier. The higher this figure, the greater the intermod rejection capability of the amplifier.

Table 1: The relationship of the *A* and *B* input signal levels, the third-order intercept point and the intermod levels at the amplifier output.

Column	A	B	C	D	E	F	G
TOIP	+5	+10	+20	+20	+20	+20	+20
A	-10	-10	-10	-13	-9	+10	+20
B	-10	-10	-10	-13	-9	+10	+20
2A-B	-40	-50	-70	-79	-67	-10	+20
2B-A	-40	-50	-70	-79	-67	-10	+20

plied to the input. Third-order intermod signals, $2A - B$ and $2B - A$, will appear at the output of the amplifier. Other products will appear at the output as well. However, this discussion will be limited to the third-order IM products. The level of the third-order IM products at the ampli-

IM signal.

Taking a final look at Table 1, examine column G. Here, the input signals are equal to the TOIP of the amplifier and the IM signals are equal to the input signal levels. This theoretical point can never be reached in practice be-

cause the amplifier would become practically inoperative before this point is reached.

Transmitter-produced IM

The class C output stage of a transmitter is fertile ground for the production of intermod. By design,

it is non-linear, rich in harmonics and connected to an antenna. Let's look at a typical two-signal IM product of the third order that is capable of interfering with a nearby receiver. We will assign some frequencies and calculate an approximate level for the IM signal. Then we will apply some solutions and check the final outcome.

Figure 2 shows two transmitters: *A* and *B*. Receiver *C* is operating at a frequency that is equal to $2A - B$. The signal from transmitter *B* enters the final stage of transmitter *A* where it mixes with the signal *A* to form the $2A - B$ IM signal. This is on the frequency of receiver *C* and therefore causes interference to the receiver. The calculation of the level of the IM signal is shown at the right. Because the level of the IM signal is -79dBm , it will seriously degrade the performance of the receiver. Steps must be taken to suppress the IM signal to a non-interfering level. The amount of suppression necessary will depend on the site noise level and the minimum necessary receive level.

Figure 3 shows that to suppress the IM signal to a non-interfering level, a bandpass cavity filter and an isolator have been installed on transmitter *A* where the IM signal is produced. Figure 4 shows the selectivity curve of the bandpass filter. Note that as the signal from transmitter *B* passes through the filter, it is attenuated by 20dB. The isolator offers another 35dB of attenuation to signal *B* before it reaches the final amplifier stage of transmitter *A*.

Still, an IM signal is formed in transmitter *A* and travels back up the line through the isolator with negligible attenuation. But in passing back through the bandpass cavity filter, the IM signal is attenuated by 20dB. This means that the IM signal leaving the antenna and reaching receiver *C* is 75dB down from what it was before the isolator and cavity filter were installed.

In this case, we did not gain any leverage in reducing the IM signal. To realize any leverage, both signals, or at least the signal with the

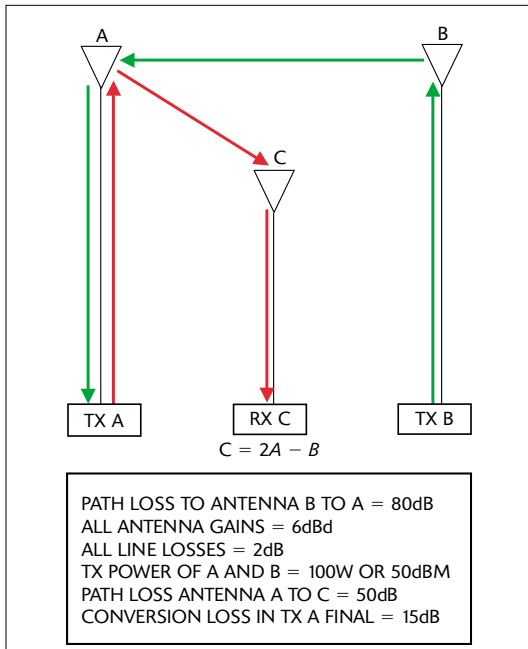

Figure 2: The signal from TX B (shown in green) enters the final stage of TX A, where it mixes with the signal from TX A to form the intermod signal, $2A - B$ (shown in red). This IM signal, at the frequency of RX C, causes interference to RX C. The IM level at the input of RX C is -79dBm . See below for calculations.

TRANSMITTER B	+50dBm
LINE LOSS B	-02
ANT. GAIN B	+06
PATH LOSS ANT. B TO A	-80
ANT. GAIN A	+06
LINE LOSS A	-02
CONVERSION LOSS TX A	-15
LINE LOSS A	-02
ANT. GAIN A	+06
PATH LOSS ANT A TO C	-50
ANT. GAIN C	+06
LINE LOSS C	-02
INPUT TO RX C	-79dBm

coefficient greater than one, must pass through some attenuation ahead of the mixing point. Another mixing point that could generate the $2A - B$ IM signal is in transmitter B. However, the IM generated there would be at a much lower level because of the leverage effect. This is because the A signal would be attenuated by the path loss between the two transmitters. Because this attenuation would be leveraged by a factor of two, the resulting IM signal in transmitter B would be of such a

low level as to be inconsequential.

Receiver-produced intermod

There is a third point in Figure 2 where the $2A - B$ IM signal could form. It is in the receiver itself. If the receiver front end were sufficiently overloaded, it would become nonlinear and become a good mixing point for the production of IM products. (See Figure 5.) In this situation, it is possible to get leverage from suppressing the IM signals. Remember, if both IM forming signals (A and B) are attenuated prior to the mixing point, the amount of reduction in the IM level is leveraged by a factor equal to the sum of the coefficients of the individual signals, A and B.

In Figure 6, an attenuator is placed between the antenna and the receiver input so that the individual signals, A and B, must pass through the attenuator. If the attenuator is set to 3dB, then we will realize a 9dB reduction in the $2A - B$ IM signal. This gives us real leverage in dealing with the IM problem. Because the desired signal must also pass through the attenuator, it will also be attenuated by 3dB. So the net gain, in terms of carrier-to-interference ratio, will be 6dB. In a situation where the IM is of low amplitude and the site noise is high, a simple resistive attenuator might be all that is needed to resolve the problem.

Usually, the cure is not that simple. It becomes a matter of selectivity ahead of the receiver. The more selectivity that exists ahead

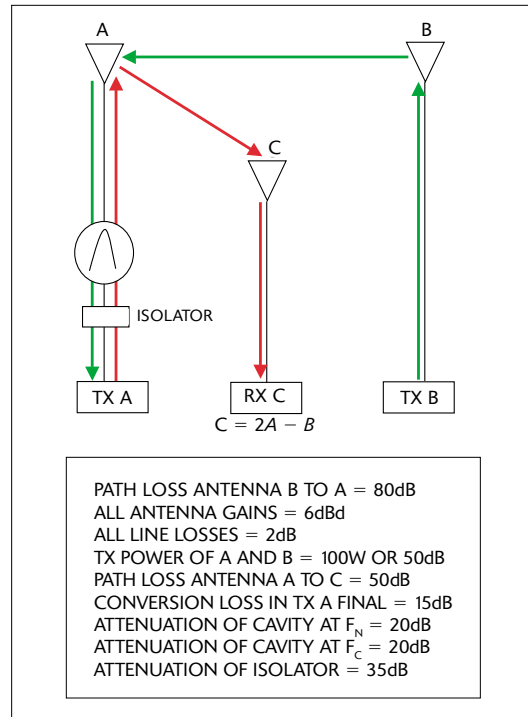

Figure 3: An isolator and a bandpass cavity have been added in the line at TX A. This provides an additional 75dB of suppression of the intermod signal. This places the intermod signal at the input of RX C at a level of -154dBm . This is well below the receiver sensitivity threshold. Thus, the IM is dead and buried. See below for the calculations.

TRANSMITTER B	+50dBm
LINE LOSS B	-02
ANT. GAIN B	+06
PATH LOSS ANT. B TO A	-80
ANT. GAIN A	+06
LINE LOSS A	-02
CONVERSION LOSS TX A	-15
LINE LOSS A	-02
ANT. GAIN A	+06
PATH LOSS ANT A TO C	-50
ANT. GAIN C	+06
LINE LOSS C	-02
CAVITY ATTENUATION TX B	-20
ISOLATOR ATTENUATION	-35
CAVITY ATTENUATION TO IM	-20
INPUT TO RX C	-154dBm

of the first active receiver stage, the better is the IM rejection capability of the receiver. It may be necessary to connect two or three bandpass cavity filters in cascade to achieve sufficient suppression of the IM signal. (See Figure 7.) This bandpass response curve represents a bandpass filter arrangement placed in front of the

receiver. The response of the filter is such that the attenuation at the desired receiver frequency (154MHz) is 2dB. The attenuation at frequency *A* (155MHz) is 10dB. This will be leveraged by a factor of two from the IM form of $2A - B$. The attenuation at frequency *B* (156MHz) is 25dB. Thus the total reduction in the IM signal in the receiver is:

$$2(10) + 25 = 45\text{dB}$$

Another possible filter method uses a notch filter. If it is desired to notch out both signals, *A* and *B*, two notch filters would be required. If we can only use a single notch filter, we have to choose which of the two IM-forming signals to notch. It would be best to notch out the *A* signal (155MHz) because a leverage factor of two would be realized. If we choose to notch out the *B* signal (156MHz) no leverage would be realized and we would only achieve a decibel for decibel reduction in the IM signal. To notch out both of these signals would require two notch cavities.

The advantage of using notch cavities is that more attenuation (at a specific frequency close to the desired frequency) can be achieved than with bandpass cavities. The disadvantage is that the notch filter only helps at one frequency while the bandpass filter helps at many frequencies outside the passband of the filter. The choice of which type of filter to use will depend on the degree of suppression needed and the spacing relative to the desired receive signal.

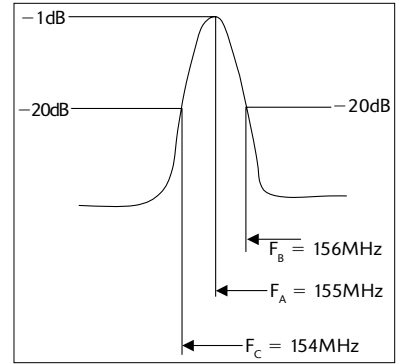

Figure 4: A cavity filter with this selectivity characteristic is placed in the TX *A* line. The center frequency at 155MHz passes the normal TX *A* signal with little attenuation. The attenuation at the frequency of TX *B* is 20dB, and the attenuation at RX *C* frequency (the intermod signal) is 20dB. So, this filter provides dual action to suppress the IM signal.

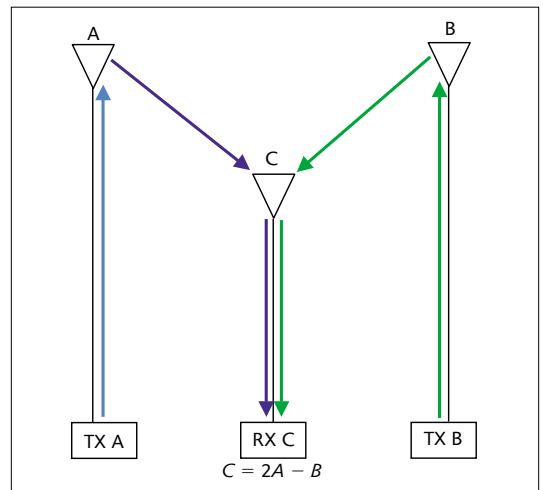

Figure 5: The signal from TX *A* (shown in blue) and the signal from TX *B* (shown in green) enter the front end of RX *C* where they mix to form the intermod signal, $2A - B$. This IM signal, at the frequency of RX *C*, causes severe interference to RX *C*.

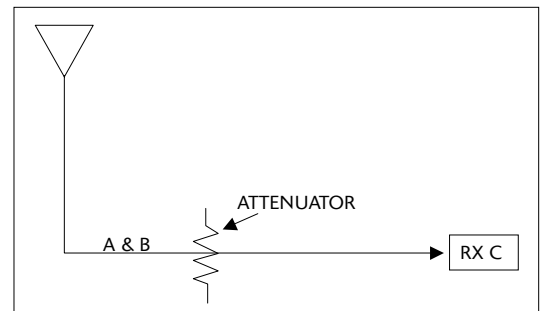

Figure 6: A simple attenuator is placed ahead of the receiver so that the *A* and *B* signals must pass through it before getting into the receiver. This simple attenuator can provide leverage in suppressing the IM signal.

Crystal filters are now available for operation at VHF highband range and can provide excellent selectivity. Typically, the crystal filter has a comparatively high insertion loss at the desired pass frequency. Some IM generation is also inherent in crystal filters, but the good usually outweighs the bad, yielding a positive net result.

Many times interference is called intermod when it really isn't intermod. Spurious signals are not always the result of intermodulation. One telltale sign of intermod is a signal that might be heard in the middle of a conversation then cut off abruptly. Another sign is an over-deviated signal. The key to suppressing the IM signal is identifying the mixing point and the individual component signals that form the IM. It is possible to have a combination of mixing points. For example, there might be a combination of transmitter-produced IM and receiver-produced IM. When suppression techniques are applied to the transmitter, the results might first appear promising. Then, further efforts might not yield further results. If the IM from the transmitter is suppressed below the level of the IM produced in the receiver, the receiver-produced IM will become the dominant IM and suppression techniques must be applied at the receiver.

For further reading, I highly recommend *Intermod Control* by William F. Lieske Sr., founder and retired president of EMR. I con-

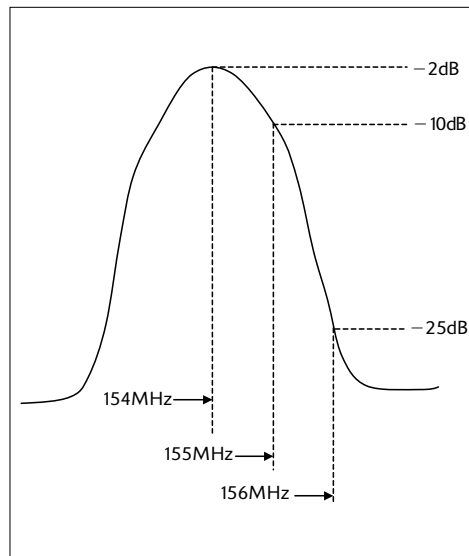

Figure 7: Two or three bandpass cavities connected in cascade could provide a bandpass selectivity such as this to suppress the IM signal level in the receiver. Note that the normal receiver frequency is placed in the center of the passband of the filter to offer little attenuation to the desired signal. The *A* signal is attenuated by 10dB and this will be leveraged by a factor of two while the *B* signal is attenuated by 25dB. This results in a 45dB reduction in the IM signal produced in the receiver.

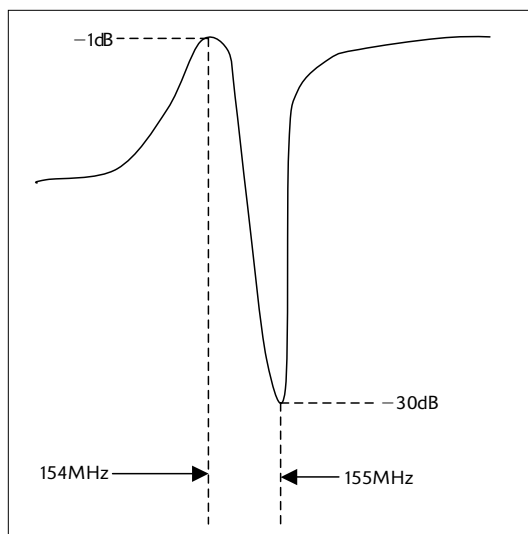

Figure 8: A notch filter such as this can be used to suppress the IM signal. The desired receiver signal at 154MHz is attenuated only 1dB, while the *A* signal at 155MHz is attenuated by 30dB. This 30dB is leveraged by a factor of two so the result is a 60dB reduction in the IM signal.

sider it the definitive work on intermodulation interference. Until next time—*stay tuned!* ■